

# M16 TCI, 180 kW VEHICLE ENGINES

## FACTS

- Rated power: 180 kW
- Torque: up to 550 Nm @ 1800 rpm
- Dry weight: 255 kg

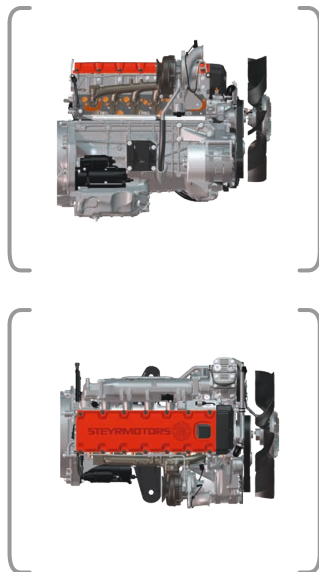
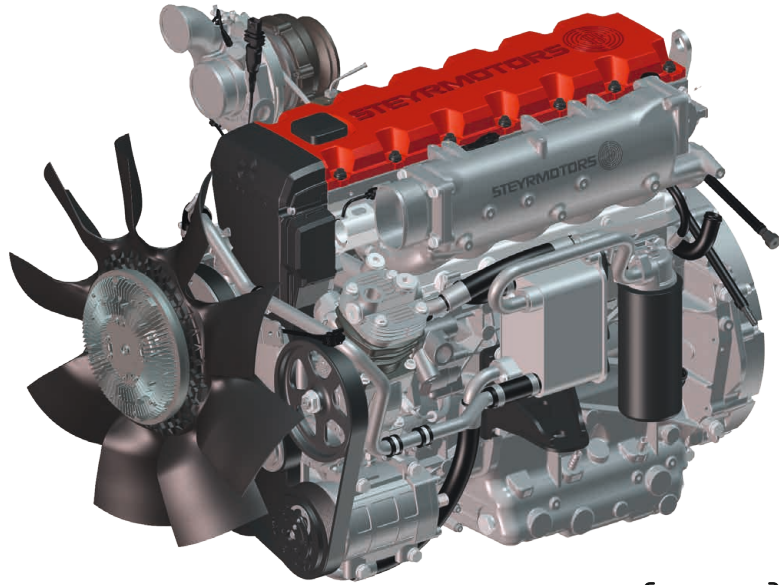

The M16 UI is the star of our product portfolio due to its vast field of application and its well-developed concept facilitating adaptations to customize the unit injection engine for individual requirements. The 6-cylinder diesel engine is available in several basic models with a wide variety of engine components such as oil sumps, front-end accessory drives and transmission flanges.

## MAIN FEATURES

- Monoblock design with excellent water cooling
- Turbocharged - single stage VTG intercooled
- Direct intercooling
- Standard operational range: from -32°C to +49°C, extended operational range possible
- Released fuel types: EN590, Jet A-1 (NATO code F-35) other fuel types on request respectively according to customer specification
- Remarkable power to weight ratio, compact design
- High robustness and durability
- Outstanding performance in high altitudes



See more applications on our website or contact us for further references.

# M16 TCI, 180 kW SPECIFICATION

<b>M16 TCI – 180-0-A</b> 180 KW MODEL	
<b>COMBUSTION SYSTEM</b>	Direct Injection Diesel
<b>DISPLACEMENT (LT)</b>	3,2
<b>BORE (MM)</b>	85
<b>STROKE (MM)</b>	94
<b>CHARGING SYSTEM</b>	turbocharged - single stage VTG intercooled
<b>RATED POWER (KW/HP)*</b>	180/245
<b>RATED SPEED (RPM)</b>	3500
<b>MAX. TORQUE (NM @ RPM)*</b>	550 @ 1800
<b>MIN. FUEL CONSUMPTION (G/KWH)*</b>	205
<b>DRY WEIGHT (KG)</b>	255

\* based on Diesel EN 590

## OVERALL CHARACTERISTICS

- ➔ 4-stroke, turbocharged
- ➔ Perfectly suited for customizing to your specific requirements

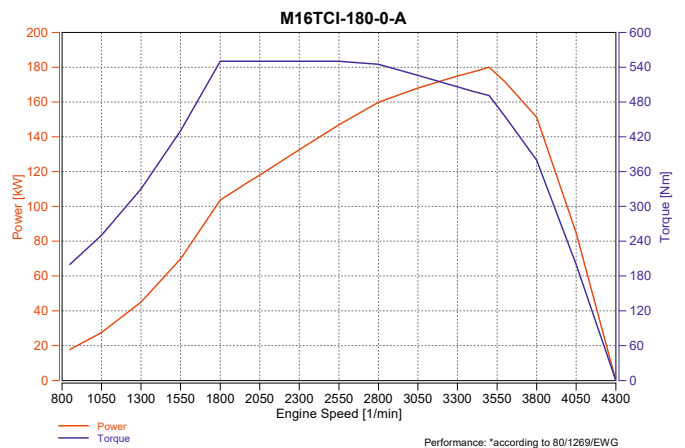

# M16 TCI, 180 kW DIMENSIONS

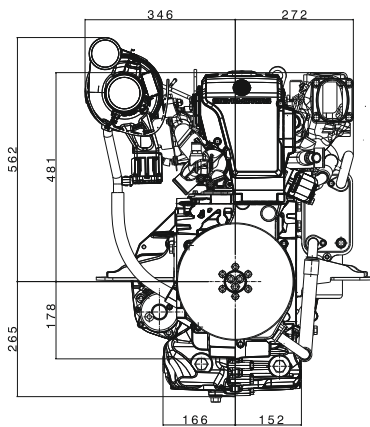
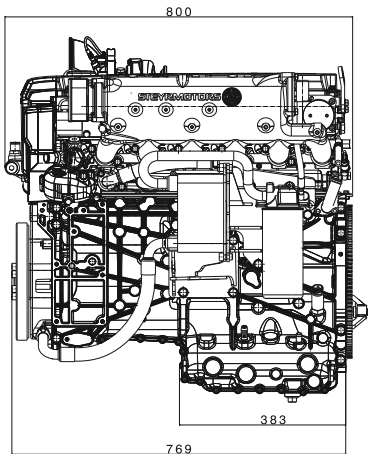

Standard base engine for vertical installation with full flexibility for customer specific FEAD and transmission interface. Deep Fording and EMV mil.461-E upgrade potential.

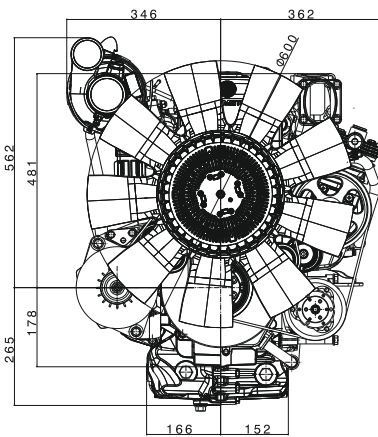
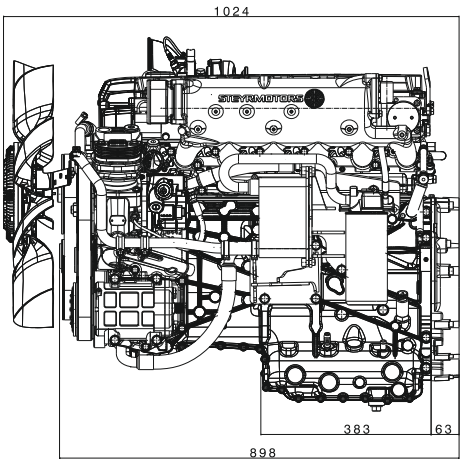

Standard base engine for vertical installation with full equipped FEAD and transmission interface for ZF8HP90 or Allison S1000 / S2000 / S2500 series. Deep Fording and EMC mil.461-E upgrade potential.

FEAD aggregates:  
 Alternator 28V-100A and 28 V-275 A  
 air compressor 150 ccm 10 bar  
 hydr. pump 17cm<sup>3</sup>/rev 16l/min 183 bar  
 AC compressor 200 cm<sup>3</sup>  
 visco fan Ø600 (electric controlled)

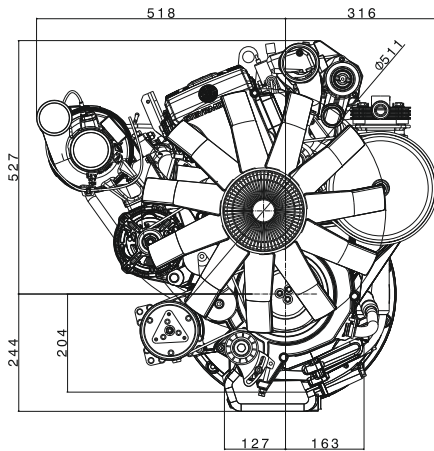
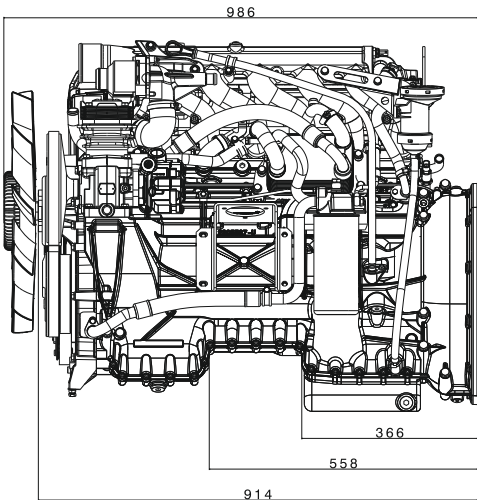

Standard base engine for 23° inclined installation with full equipped FEAD and transmission interface for Allison S1000 / S2000 / S2500 series. Limited flexibility for FEAD aggregates and transmissions.

FEAD aggregates:  
 Alternator 28V-100A  
 air compressor 150 ccm 10 bar  
 hydr. pump 17cm<sup>3</sup>/rev 16l/min 183 bar  
 AC compressor 155 cm<sup>3</sup>  
 visco fan Ø500

# VEHICLE ENGINES



The details and related materials provided in this brochure are subject to change without prior notice. We reserve the right to revise specifications and design as well as to correct misprints and errors. Actual products may differ in appearance from images shown. Dimensions given within this brochure are in mm. They may differ according to engine types and are not applicable for installations.