



**STEYR CONTROL CENTER  
SCC**

**I/O-Box**





## Contents

<b>MAIN UNIT SCC</b>	<b>3</b>
<b>4-PIN CONNECTORS</b>	<b>3</b>
<b>6-PIN CONNECTOR</b>	<b>4</b>
<b>I/O-BOX</b>	<b>5</b>
<b>4-PIN CONNECTORS</b>	<b>5</b>
<b>8-PIN CONNECTOR</b>	<b>6</b>
<b>12-PIN CONNECTOR</b>	<b>8</b>
<b>FUSES</b>	<b>11</b>
<b>TECHNICAL DATA</b>	<b>14</b>
<b>SCC</b>	<b>14</b>
<b>I/O-Box</b>	<b>14</b>

## Main unit SCC

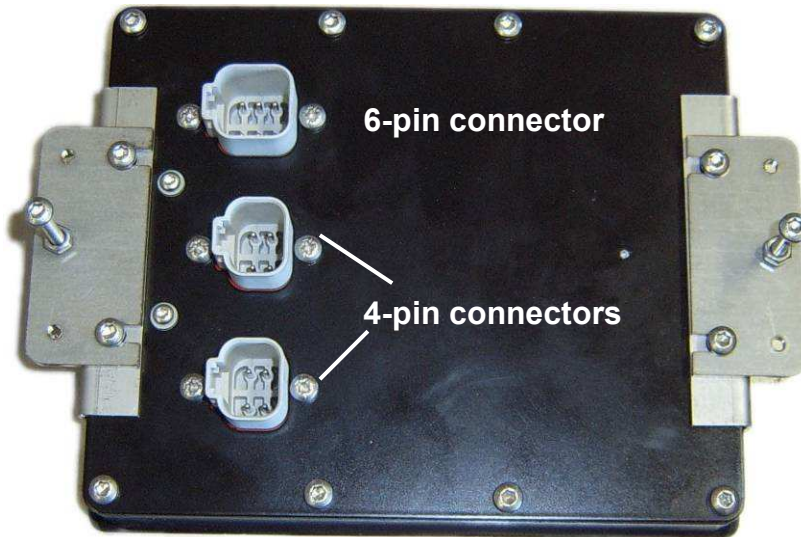

## 4-pin connectors

### Pin numbers

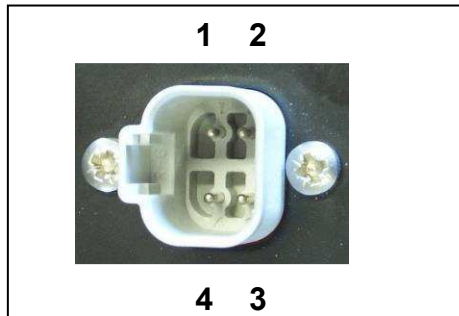

Pin	Signal	Type
1	Ignition +12V or +24V min. 10V max. 30V	Power supply of SCC
2	CAN high	Data
3	CAN low	Data
4	Power ground Do not connect with "Signal ground"!	Power supply of SCC

**Table 1: Pin assignment SCC 4-pin connector**

## 6-pin connector

### Pin numbers

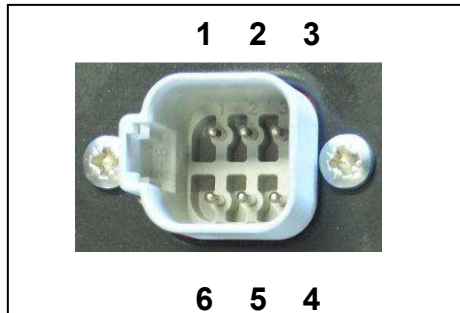

Pin	Signal	Type
1	Steady plus +12V or +24V min. 10V max. 30V To supply heater option of SCC although Ignition is off. SCC will not work if only supplied with Steady plus. For GND use "Power ground" from other connector. When using steady plus, be sure that the cable for "Power ground" is not longer than 1m from the panel to the SCC.	Additional power supply of heater option of SCC
2	USB positive	Data
3	USB negative	Data
4	GPS in	Data RS232 level
5	GPS power (built in auto resetting fuse) Delivers power from Ignition to the GPS receiver. Same voltage as delivered on Ignition. Max. 200mA	Power supply for external GPS receiver.
6	Signal ground Do not connect with "Power ground"! Used to connect GPS receiver and USB	Power supply of external GPS receiver

**Table 2: Pin assignment SCC 6-pin connector**

## I/O-Box

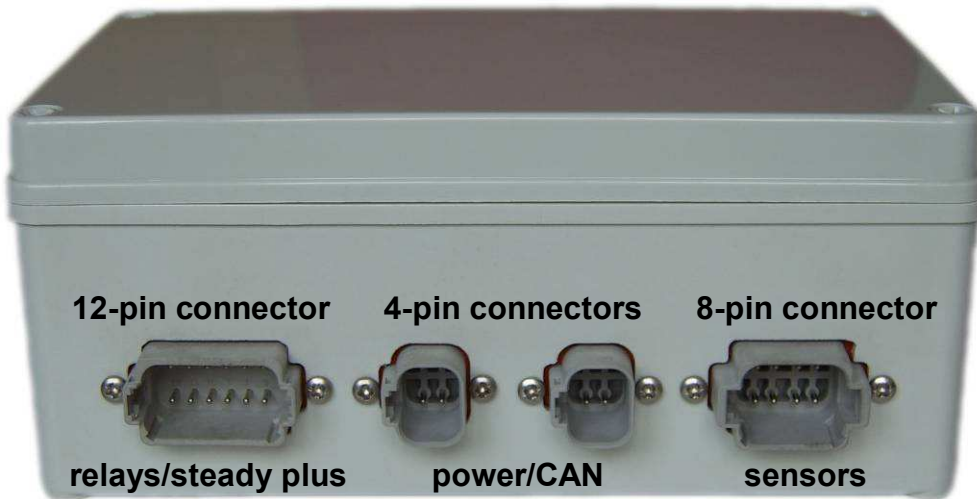

### 4-pin connectors

#### Pin numbers

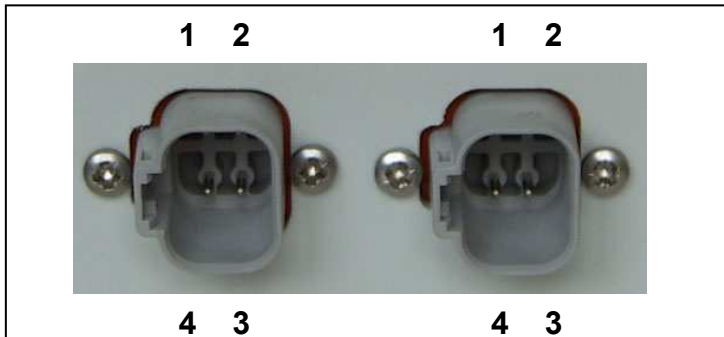

Pin	Signal	Type
1	Ignition +12V or +24V min. 10V max. 30V	Main power supply of I/O-Box
2	CAN high	Data
3	CAN low	Data
4	Power ground	Main power supply of I/O-Box

Table 3: Pin assignment I/O-Box 4-pin connector

## 8-pin connector

### Pin numbers

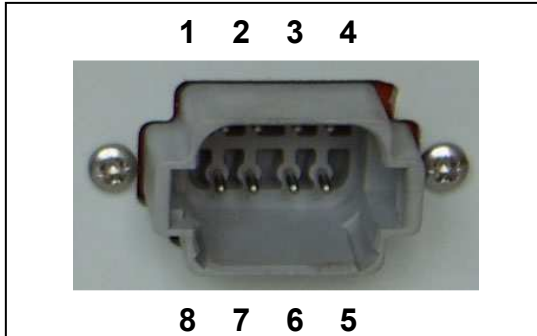

Pin	Signal	Type
1	Sensor 1 plus Do not connect with other sensor pins	Sensor
2	Sensor 2 plus Do not connect with other sensor pins	Sensor
3	Sensor 3 plus Do not connect with other sensor pins	Sensor
4	Sensor 4 plus Do not connect with other sensor pins	Sensor
5	Sensor 4 GND Do not connect with other sensors GND! Do not connect with "Power GND"! Do not connect with "Signal GND"!	Sensor
6	Sensor 3 GND Do not connect with other sensors GND! Do not connect with "Power GND"! Do not connect with "Signal GND"!	Sensor
7	Sensor 2 GND Do not connect with other sensors GND! Do not connect with "Power GND"! Do not connect with "Signal GND"!	Sensor
8	Sensor 1 GND Do not connect with other sensors GND! Do not connect with "Power GND"! Do not connect with "Signal GND"!	Sensor

**Table 4: Pin assignment I/O-Box 8-pin connector**

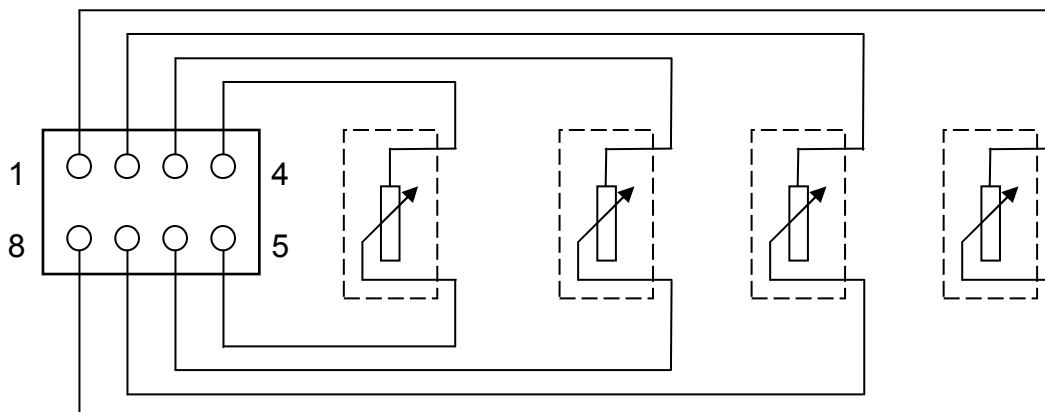

**Drawing 1: Connecting sensors**

Use separate cables for each sensor!  
Do not connect sensors together!  
Do not connect one sensor with multiple inputs!

## 12-pin connector

### Pin numbers

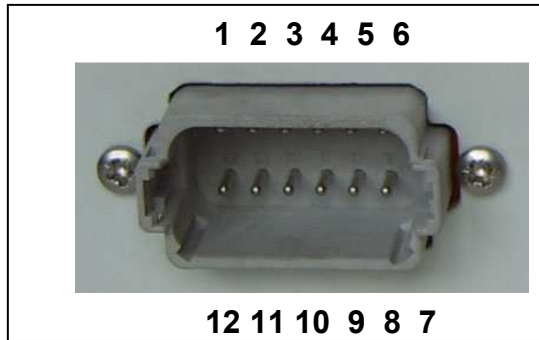

Pin	Signal	Type
1	Relay-1a (built in 15A fuse) max. 13A	Relay
2	Relay-2a (built in 15A fuse) max. 13A	Relay
3	Relay-3a (built in 15A fuse) max. 13A	Relay
4	Relay-4a (built in 15A fuse) max. 13A	Relay
5	not connected	
6	Steady plus +12V or +24V min. 10V max. 30V To supply I/O-Box although Ignition is off. If ignition loses power, the I/O-Box is still working and all relays keep there current state.	Additional power supply of I/O-Box
7	Power ground Internally connected to Power ground of 4-pin connector Can be used together with pin 6 to supply I/O-Box although Ignition is off. Do not connect with relay pins. For relays use separate ground cable and not this pin.	Power supply of I/O-Box
8	not connected	
9	Relay-4b	Relay
10	Relay-3b	Relay
11	Relay-2b	Relay
12	Relay-1b	Relay

**Table 5: Pin assignment I/O-Box 12-pin connector**

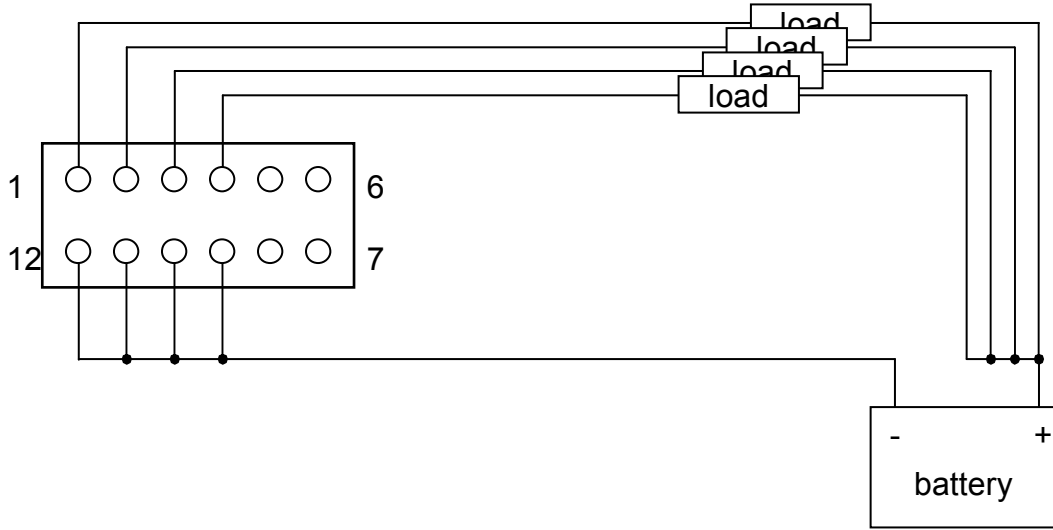

**Drawing 2: Variant A - connecting loads to the relays**

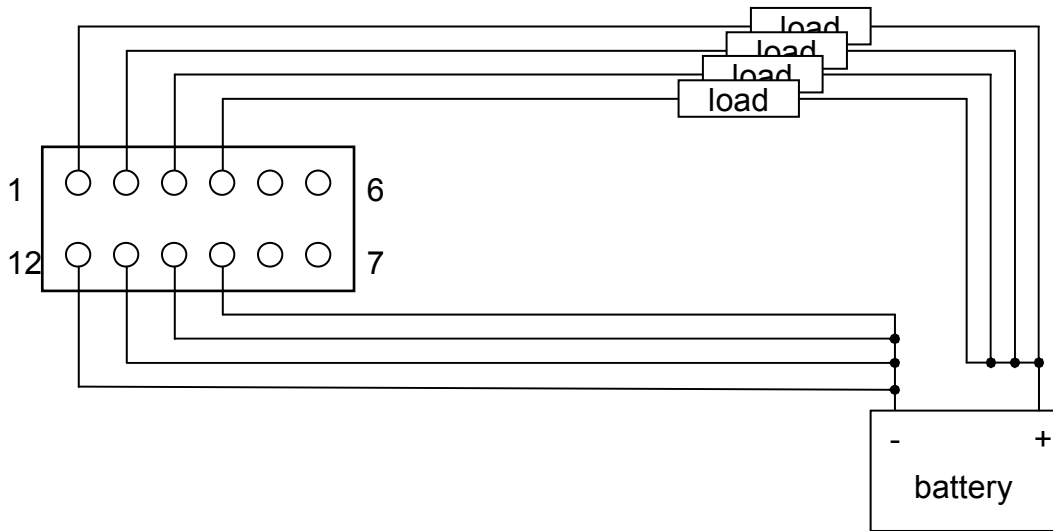

**Drawing 3: Variant B - connecting loads to the relays**

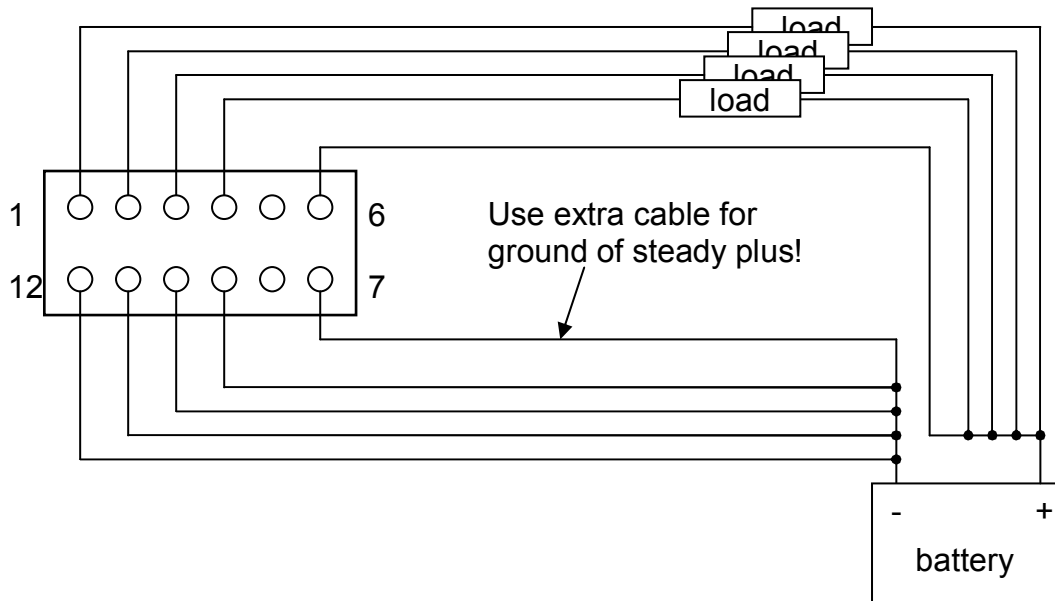

**Drawing 4: connecting steady plus to I/O-Box**

When connecting steady plus of the I/O-Box, use separate ground- and power cables. Do NOT use the same ground cable for pin 7 (Power ground of steady plus) and the relay pins!

## Fuses

In case it's necessary to change fuses of the I/O-Box please follow these steps:

- Make sure that you have spare fuses of the type described below
- Turn off power and remove all cables from the I/O-Box
- Put the I/O-Box into a dry and clean place
- Open the four screws of the I/O-Box cover with a fitting screwdriver and open the cover

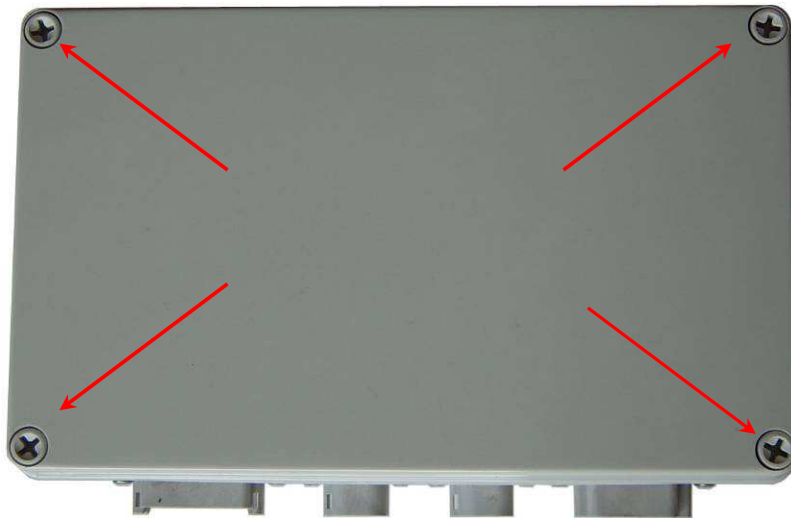

- Find the position of the fuse cover

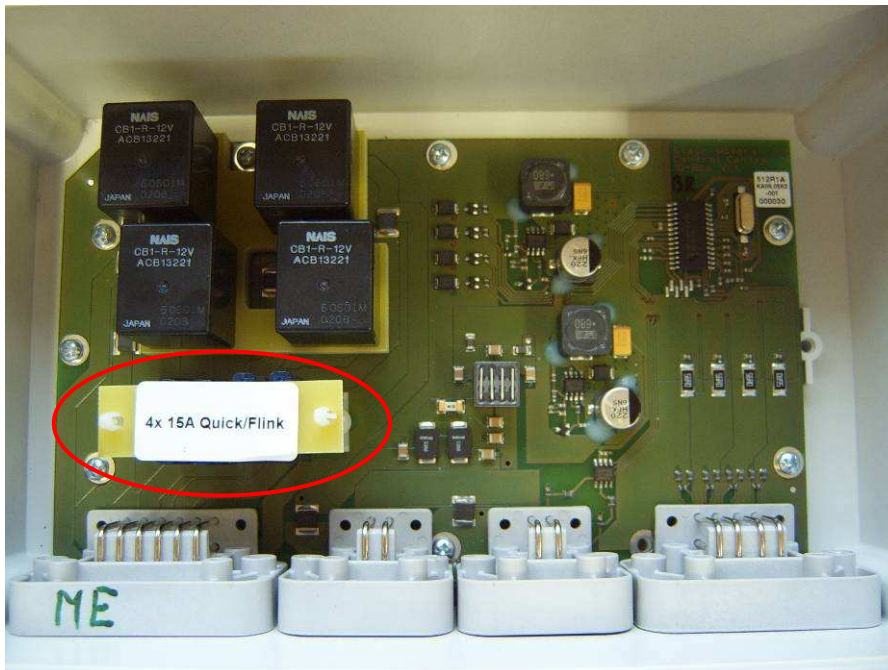

- Do not touch any electronic components except the fuses!

- Carefully press the lock of the fuse cover holder on one side and lift the fuse cover a little

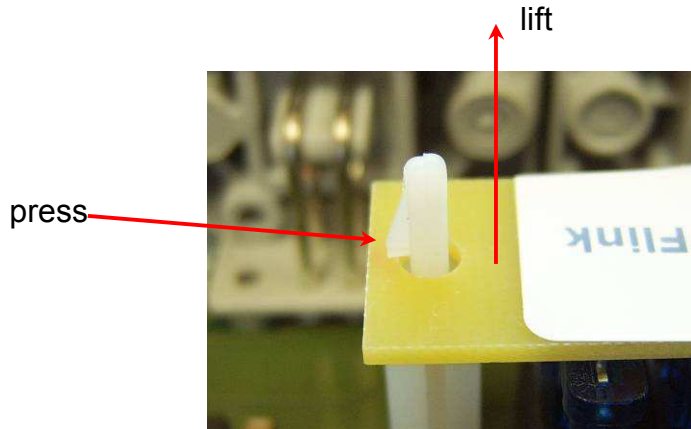

- Carefully press the lock of the fuse cover holder on the other side and lift the fuse cover a little

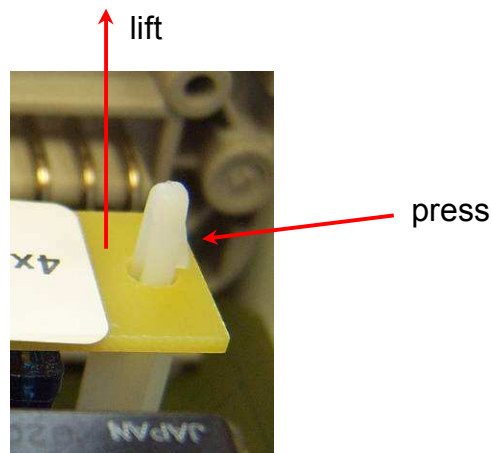

- Remove the fuse cover carefully. Now you can see the fuses

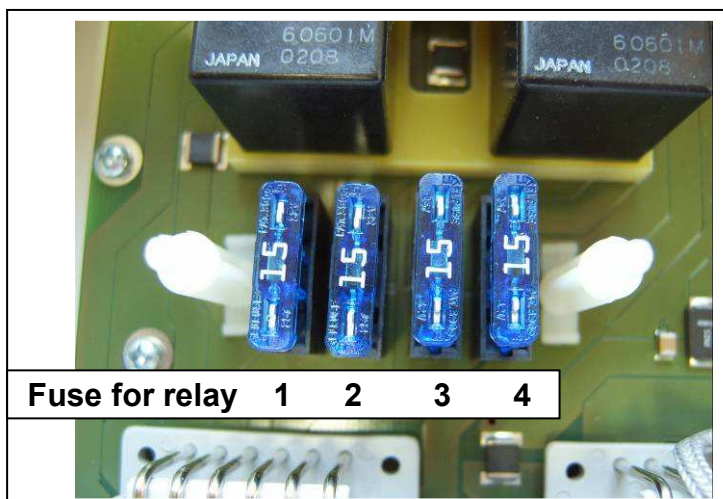

- Change the blown fuses
- Put back the fuse cover. Ensure it's locked completely at the pin.
- Take a look at the black gasket in the I/O-Box cover and at the edge of the box. Both must be clean before putting the cover onto the box!  
Be sure that it's not rotated 180°. Look at the edges of the box and the cover!  
Put the tongue of the cover into the groove of the box.  
Put the tongue of the box into the groove of the cover.

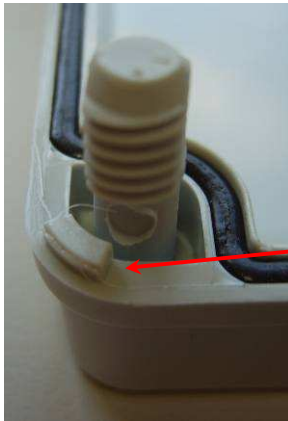

matches



matches



- Screw down the four screws of the cover.  
**IMPORTANT:** All screws must be firmly screwed down to ensure that the box is waterproof!

## Technical data

### SCC

Dimensions without protection cap	192 x 162 x 70,5mm
Height without connector	62mm
Height with cables connected	approx. 100 to 110mm
Height above flange	23mm
Weight SCC without mounting material	1.5 kg
Weight standard mounting material	0.1 kg
Protection class	IP67
Operating temperature (ambient)	-10°C to 55°C / 14°F to 131°F
Operating voltage	10 – 30V DC
Current consumption at room temperature, full backlight	typ. 510mA @ 12V typ. 270mA @ 24V
Additional current consumption for the heater <sup>1</sup> (The heater only uses current when the device is too cold for normal operation)	max. 1A @ 12V typ. rms value 0.5A @ 24V

### I/O-Box

Dimensions without mounting clip	230 x 140 x 98mm
Weight	1.1 kg
Protection class	IP67
Operating temperature	-10°C to 55°C / 14°F to 131°F
Operating voltage	10 – 30V DC
Current consumption all relays off at room temperature	typ. 25mA @ 12V typ. 16mA @ 24V
Current consumption all relays on at room temperature	typ. 300mA @ 12V typ. 150mA @ 24V
Optimal Resistor range for sensors	0 – 200Ω
Maximal current at relay pins	13A
Fuses	4x Fast-acting ATO fuse 15A blue according to U.L. Standard for Automotive Blade Type Fuses. SAE J1284.

<sup>1</sup> SCC with heater must be purchased extra. It is not possible to equip existing SCCs with heaters. The heater is needed to use the SCC at deep temperatures below -10°C/14°F.